

**M9208-GGx-1 Series
Proportional Electric Spring Return Actuators**

Application

The **JOHNSON CONTROLS SPRING RETURN** electric damper-actuator series has been specially developed for the motorized operation of air dampers in air conditioning systems. When the control signal is applied the actuator drives the damper to the operational position, while evenly tensioning the integrated spring. After a power failure the stored energy in the spring immediately brings the damper to the safety position. Manual operation is automatically cancelled when the actuator is in electrical operation. The compact design and universal adapter fitted with limitation of rotation angle make this actuator highly versatile.

Features

- 0(2)..10 V or 0(4)..mA control signal
- Up to 5 actuators in parallel operation possible
- Electrical connection with halogen-free cable
- Simple direct mounting with universal adapter on Ø 8 mm to 16 mm shaft or 6 mm to 12 mm square shaft. An optional M9208-600 Jackshaft Coupler Kit is available for 12 to 19 mm round shafts, or 10 mm to 14 mm square shafts
- Limitation of rotation angle
- Manual positioning with crank handle
- 2 auxiliary switches, 1 adjustable (See page 4 for settings)



Ordering Codes

Codes	Descriptions
M9208-GGA-1	8 Nm, Proportional, 24 V AC/DC
M9208-GGC-1	8 Nm, Proportional, 2 auxiliary switches, 24 V AC/DC

Accessories and Replacement Parts

(Order Separately)

Codes	Descriptions
M9000-604	Replacement Anti-Rotation Bracket Kit for M9208, M9210 and M9220 Series Electric Spring Return Actuators (quantity 1)
M9208-100	Remote Mounting Kit, including Mounting Bracket, M9208-150 Crankarm, Ball Joint and mounting fastener (quantity 1)
M9208-150	Crankarm (quantity 1)
M9208-600	Large Shaft Coupler Kit (with Locking Clip) for Mounting M9208-xxx-1 Series Electric Spring Return Actuators on dampers with round shafts from 12 to 19 mm or square shafts from 10 to 14 mm (quantity 1)
M9208-601	Replacement Standard Coupler Kit (with Locking Clip) for mounting M9208-xxx-1 Series Electric Spring Return Actuators on dampers with round shafts from 8 to 16 mm or square shafts from 6 to 12 mm (quantity 1)
M9208-602	Replacement Locking Clips for M9208-xxx-1 Series Electric Spring Return Actuators (quantity 5)
M9208-603	Adjustable Stop Kit for M9208-xxx-1 Series Electric Spring Return Actuators (quantity 1)
M9208-604	Replacement Manual Override Cranks for M9208 Series Electric Spring Return Actuators with long crank radius: 72 mm (quantity 5)
M9208-605	Replacement Manual Override Cranks for M9208 Series Electric Spring Return Actuators with short crank radius: 46.5 mm (quantity 5)

**M9208-GGx-1 Series
Proportional Electric Spring Return Actuators**

Technical Specifications

Actuator	M9208-GGx-1
Power Requirements	24 V AC/DC at 50/60 Hz (AC 19.2 to 28.8 V) - 24 V DC (DC 21.6 to 28.8 V)
- Running (AC)	7.9 VA
- Holding Position (AC)	5.5 VA
- Running (DC)	3.5 W
- Holding Position (DC)	1.9 W
Transformer Sizing Requirements	
- Minimum per Actuator	8 VA
Input Signal/Adjustments	Factory Set at DC 0 to 10 V, CW Rotation with Signal Increase; Selectable DC 0(2) to 10 V or 0(4) to 20 mA with Field-Furnished 500 ohm, 0.25 W Minimum Resistor; Switch Selectable Direct or Reverse Action with Signal Increase
Control Input Impedance	Voltage Input: 100,000 ohms; Current Input: 500 ohms with Field Furnished 500 ohm Resistor
Feedback Signal	DC 0(2) to 10 V for Desired Rotation Range up to 95° Corresponds to Rotation Limits, 0.5 mA at 10 V Maximum
Auxiliary Switch Rating	Two Single-Pole, Double-Throw (SPDT), Double-Insulated Switches with Gold Flash Contacts: AC 24 V, 50 VA Pilot Duty; AC 240 V, 5.0 A Resistive, 1/4 hp, 275 VA Pilot Duty
Spring Return	Direction is Selectable with Mounting Position of Actuator: Side A, Actuator Face Away from Damper for CCW Spring Return; Side B, Actuator Face Away from Damper for CW Spring Return
Running and Spring Return Torque	8 Nm at all operating temperature
Rotation Range	Maximum Full Stroke: 95° Adjustable Stop: 35° to 95° Maximum Position
Rotation Time for 90° of travel	
- Power On (Running)	150 Seconds Constant for 8 Nm Load, at all Operating Conditions
- Power Off (Spring Returning)	17 to 25 Seconds for 0 to 8 Nm Load, at Room Temperature 22 Seconds Nominal at Full Rated Load 94 Seconds Maximum with 8 Nm Load, at -40 °C
Cycles	60,000 Full Stroke Cycles; 1,500,000 repositions
Audible Noise Rating	
- Power On (Running)	<35 dBA at 8 Nm Load, at a Distance of 1 m
- Power On (Holding)	<20 dBA at a Distance of 1 m
- Power Off (Spring Returning)	<52 dBA at 8 Nm Load, at a Distance of 1 m
Electrical Connections	
- Actuators (all models)	1.2 m UL 758 Type AWM Halogen-Free Cable with 0.85 mm ² (18 AWG) conductors and 6 mm ferrule ends
- Auxiliary Switches (-xxC Models)	1.2 m UL 758 Type AWM Halogen-Free Cable with 0.85 mm ² (18 AWG) conductors and 6 mm ferrule ends
Mechanical Connections	
- Standard Shaft Clamp Included with Actuator	8 to 16 mm Diameter Round Shafts, or 6 to 12 mm Square Shafts
- Optional M9208-600 Jackshaft Coupler Kit	12 to 19 mm Diameter Round Shafts, or 10 to 14 mm Square Shafts
Aluminum Enclosure	IP54 for All Mounting Orientations
Ambient Conditions	
- Operating	-40 to 60 °C; 90% RH Maximum, Noncondensing
- Storage	-40 to 85 °C; 95% RH Maximum, Noncondensing
Dimensions	See Figure
Shipping Weight	Models: -GGA: 1.6 kg Models: -GGC: 1.7 Kg
Compliance	
	EMC Directive 2004/108/EC (Models: All) Low Voltage Directive 2006/95/EC (M9208-GGC-1 Model)

M9208-GGx-1 Series
Proportional Electric Spring Return Actuators

Direction of Action

The Proportional Electric Spring Return Actuators are factory set for Direct Acting (DA) operation. In DA mode, applying an increasing input signal to the control input drives the actuator away from the spring return position. Reverse Acting (RA) operation is also available. In RA mode, applying an increasing input signal to the control input drives the actuator toward the spring return position. Figure aside indicates how to set the mode selection switch to change the behavior of the actuator.

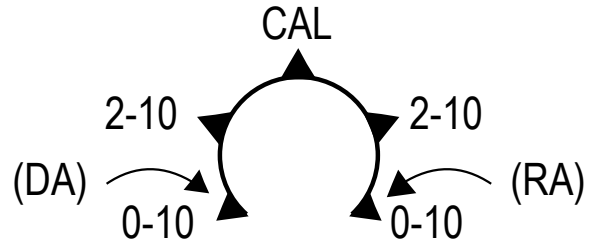

Calibration (CAL) Function

The CAL function enables the actuator to redefine the selected input signal range proportionally across a reduced rotation range. The actuator maintains calibration when power is lost or removed.

Follow these steps to calibrate the input signal range:

1. With power applied to the actuator, move the mode selection switch to the CAL position and leave it in this position for approximately 5 seconds. The actuator begins rotating until the end-stops are found.
2. Move the mode selection switch to the desired input signal range. Selection can be made while the calibration process is in progress, or after it is complete. The selected input signal is proportionally reconfigured to the reduced rotation range.

Note: During normal operation, if the actuator stroke increases due to seal or seat wear, input signal are automatically reconfigured to the increased rotation range in approximately 0.5° increments.

3. If the actuator mounting position is changed or if the linkage is adjusted, repeat Step 1 and Step 2 to repeat the CAL function.

Note: The mode selection switch must remain out of the CAL position for at least 2 seconds before re-initiating the CAL function.

Note: If the mode selection switch is left in the CAL position, the actuator defaults to 0-10 V input signal range, DA.

Control signal adjustment (Y)

Direct acting (CW)

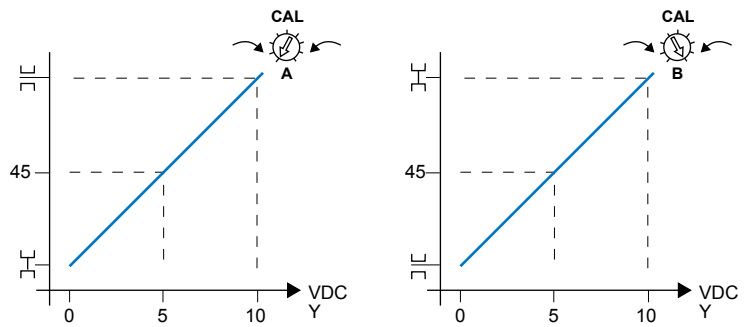

Reverse acting (CCW)

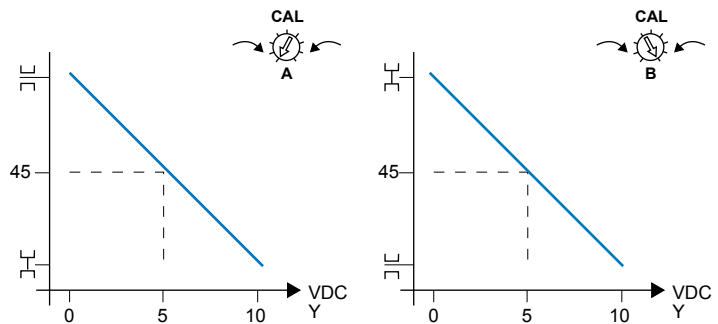

CAL-adjustment

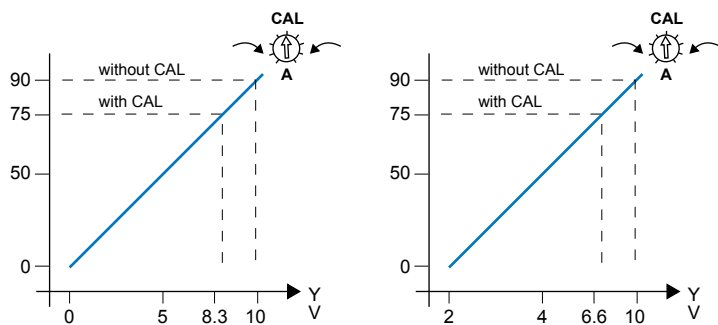

M9208-GGx-1 Series
Proportional Electric Spring Return Actuators

Wiring Diagrams

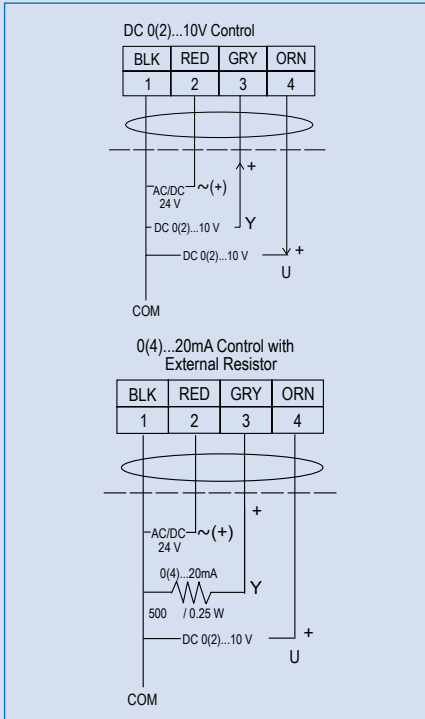

Master-Slave Application

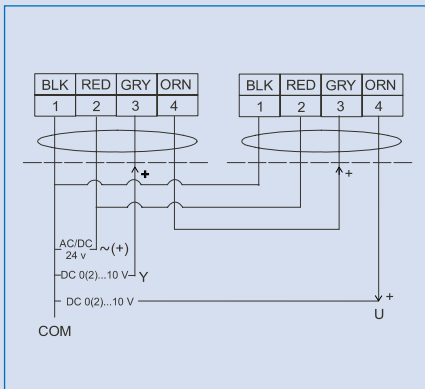

Auxiliary Switches (S)

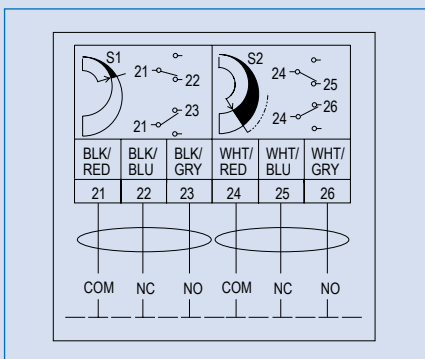

Dimensions in mm

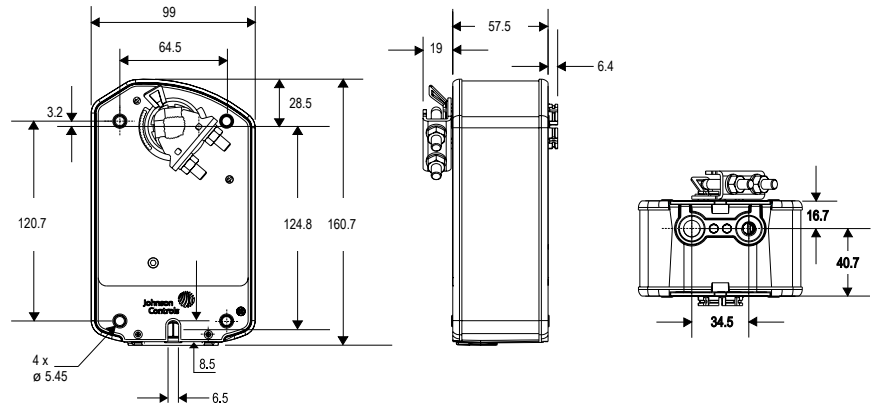

Setting the auxiliary switches

These models include two integral auxiliary switches, one fixed (S1) and one adjustable (S2), accessible on either face of the actuator. The nominal factory setting for S1 Auxiliary Switch is 11° closing, and the nominal factory setting for S2 Auxiliary Switch is 81° opening (relative to a 0 to 90° rotation range).

The switch point of S2 Auxiliary Switch is independently and continuously adjustable from 20° to 85° (relative to a 0 to 90° rotation range).

Use the method in the following example for the most accurate positioning of S2 Auxiliary Switch.

1. Move the actuator to the full spring return position.
2. Rotate the switch adjuster until it points to the desired switch point.
3. Connect S2 Auxiliary Switch to a power source or an ohmmeter, and apply power to the actuator. The actuator moves to the fully open position and holds while power is applied.
4. Observe the switch point. If required, repeat Steps 2 and 3.

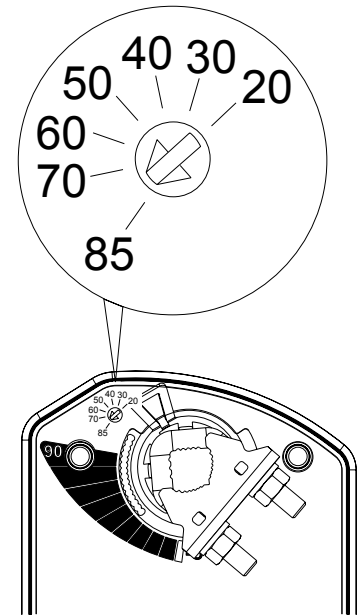

Limitation of rotation angle

Using the M9208-603 the angle of rotation can be limited. The actuator is factory set for 95° rotation, and its range is limited in 5° increments to a minimum of 35°.

Attaching the stroke-limiting stop in the furthest mounting position reduces the rotation range of the actuator by 5°. Each progressive position reduces the rotation range on additional 5°.

