

**M9208-BGx-1 / M9208-BDx-1 Series
ON/OFF Electric Spring Return Actuators**

Application

The **JOHNSON CONTROLS SPRING RETURN** electric damper-actuator series has been specially developed for the motorized operation of air dampers in air conditioning systems. When the control signal is applied the actuator drives the damper to the operational position, while evenly tensioning the integrated spring. After a power failure the stored energy in the spring immediately brings the damper to the safety position. Manual operation is automatically cancelled when the actuator is in electrical operation. The compact design and universal adapter fitted with limitation of rotation angle make this actuator highly versatile.

Features

- ON/OFF control
- Up to 5 actuators in parallel operation possible
- Electrical connection with halogen-free cable
- Simple direct mounting with universal adapter on Ø 8 mm to 16 mm shaft or 6 mm to 12 mm square shaft. An optional M9208-600 Jackshaft Coupler Kit is available for 12 to 19 mm round shafts, or 10 mm to 14 mm square shafts
- Limitation of rotation angle
- Manual positioning with crank handle
- 2 auxiliary switches, 1 adjustable (See page 3 for settings)



Ordering Codes

Codes	Descriptions
M9208-BGA-1	8 Nm, 24 V AC/DC, ON/OFF
M9208-BGC-1	8 Nm, 24 V AC/DC, ON/OFF, 2 auxiliary switches
M9208-BDA-1	8 Nm, 230 V AC, ON/OFF
M9208-BDC-1	8 Nm, 230 V AC, ON/OFF 2 auxiliary switches

Accessories and Replacement Parts (Order Separately)

Codes	Descriptions
M9000-604	Replacement Anti-Rotation Bracket Kit for M9208, M9210 and M9220 Series Electric Spring Return Actuators (quantity 1)
M9208-100	Remote Mounting Kit, including Mounting Bracket, M9208-150 Crankarm, Ball Joint and mounting fastener (quantity 1)
M9208-150	Crankarm (quantity 1)
M9208-600	Large Shaft Coupler Kit (with Locking Clip) for Mounting M9208-xxx-1 Series Electric Spring Return Actuators on dampers with round shafts from 12 to 19 mm or square shafts from 10 to 14 mm (quantity 1)
M9208-601	Replacement Standard Coupler Kit (with Locking Clip) for mounting M9208-xxx-1 Series Electric Spring Return Actuators on dampers with round shafts from 8 to 16 mm or square shafts from 6 to 12 mm (quantity 1)
M9208-602	Replacement Locking Clips for M9208-xxx-1 Series Electric Spring Return Actuators (quantity 5)
M9208-603	Adjustable Stop Kit for M9208-xxx-1 Series Electric Spring Return Actuators (quantity 1)
M9208-604	Replacement Manual Override Cranks for M9208 Series Electric Spring Return Actuators with long crank radius: 72 mm (quantity 5)
M9208-605	Replacement Manual Override Cranks for M9208 Series Electric Spring Return Actuators with short crank radius: 46.5 mm (quantity 5)

M9208-BGx-1 / M9208-BDx-1_05 2009

**M9208-BGx-1 / M9208-BDx-1 Series
ON/OFF Electric Spring Return Actuators**

Technical Specifications

Actuator	M9208-BGx-1	M9208-BDx-1
Power Requirements	24 V AC at 50/60 Hz (AC 18 to 30 V) 24 V DC (DC 21.6 to 28.8 V)	230 V AC at 50/60 Hz (AC 198 to 264 V)
- Running (AC)	6.1 VA	0.04 A
- Holding Position (AC)	1.2 VA	0.03 A
- Running (DC)	3.5 W	---
- Holding Position (DC)	0.5 W	---
Transformer Sizing Requirements		
- Minimum per Actuator	7 VA	---
Input Signal	---	---
Auxiliary Switch Rating (M9208-xxC-1)	Two Single-Pole, Double-Throw (SPDT), Double-Insulated Switches with Gold Flash Contacts: AC 24 V, 50 VA Pilot Duty; AC 240 V, 5.0 A Resistive, 1/4 hp, 275 VA Pilot Duty	
Spring Return	Direction is Selectable with Mounting Position of Actuator: Side A, Actuator Face Away from Damper for CCW Spring Return; Side B, Actuator Face Away from Damper for CW Spring Return	
Rated Torque		
- Power On (Running)	8 Nm at all operating temperatures	
- Power Off (Spring Running)	8 Nm at Standard operating temperatures 6 Nm at Extended operating temperatures	
Rotation Range	Maximum Full Stroke: 95° Adjustable Stop: 35° to 95° Maximum Position	
Rotation Time for 90°		
- Power On (Running)	55 to 71 Seconds for 0 to 8 Nm Load, at all Operating Conditions 60 Seconds Nominal at Full Rated Load (0.251 rpm)	
- Power Off (Spring Returning)	13 to 26 Seconds for 0 to 8 Nm Load, at Room Temperature 21 Seconds Nominal at Full Rated Load 39 Seconds Maximum with 8 Nm Load, at -20 °C 108 Seconds Maximum with 6 Nm load at -40 °C	
Cycles	60,000 Full Stroke Cycles	
Audible Noise Rating		
- Power On (Running)	<47 dBA at 8 Nm Load, at a Distance of 1 m	
- Power On (Holding)	<20 dBA at a Distance of 1 m	
- Power Off (Spring Returning)	<52 dBA at 8 Nm Load, at a Distance of 1 m	
Electrical Connections		
- Actuator (all models)	1.2 m UL 758 Type AWM Halogen-Free Cable with 0.85 mm ² (18 AWG) conductors and 6 mm ferrule ends	
- Auxiliary Switches (-xxC models)	1.2 m UL 758 Type AWM Halogen-Free Cable with 0.85 mm ² (18 AWG) conductors and 6 mm ferrule ends	
Mechanical Connections	8 to 16 mm Diameter Round Shafts, or 6 to 12 mm Square Shafts	
Enclosure Rating	IP 54 for All Mounting Orientations	
Ambient Conditions		
- Standard Operating	-20 to 60 °C; 90% RH Maximum, Non-condensing	
- Extended Operating	-40 to 20 °C; 90% RH Maximum, Non-condensing	
- Storage	-40 to 85 °C; 95% RH Maximum, Non-condensing	
Dimensions	See figure	
Shipping Weight	1.7 Kg	1.9 Kg
Compliance	 EMC Directive 2004/108/EC (Models: All) Low Voltage Directive 2006/95/EC (-BDx and -BGC)	

M9208-BGx-1 / M9208-BDx-1_05 2009

**M9208-BGx-1 / M9208-BDx-1 Series
ON/OFF Electric Spring Return Actuators**

Wiring Diagrams

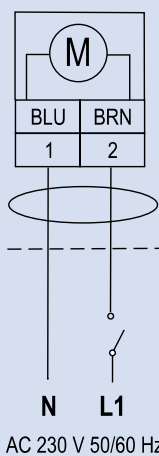
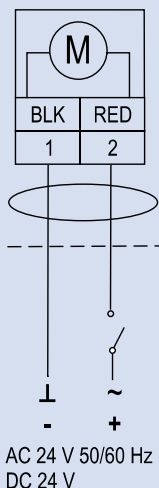

Dimensions in mm

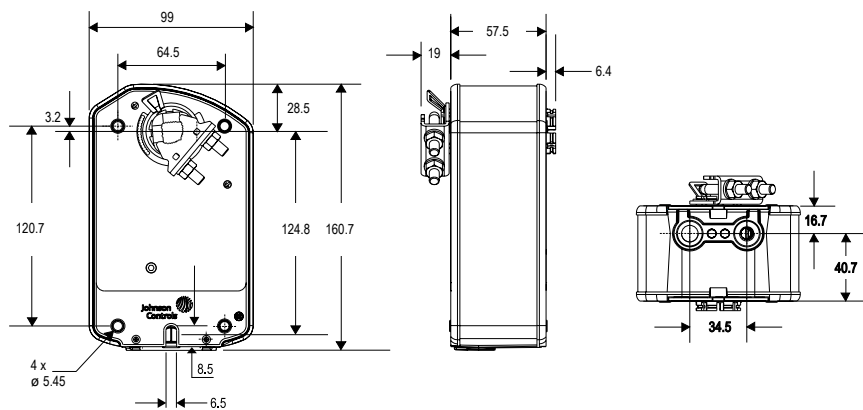

Setting the auxiliary switches

These models include two integral auxiliary switches, one fixed (S1) and one adjustable (S2), accessible on either face of the actuator. The nominal factory setting for S1 Auxiliary Switch is 11° closing, and the nominal factory setting for S2 Auxiliary Switch is 81° opening (relative to a 0 to 90° rotation range).

The switch point of S2 Auxiliary Switch is independently and continuously adjustable from 20° to 85° (relative to a 0 to 90° rotation range).

Use the method in the following example for the most accurate positioning of S2 Auxiliary Switch.

- 1. Move the actuator to the full spring return position.
- 2. Rotate the switch adjuster until it points to the desired switch point.
- 3. Connect S2 Auxiliary Switch to a power source or an ohmmeter, and apply power to the actuator. The actuator moves to the fully open position and holds while power is applied.
- 4. Observe the switch point. If required, repeat Steps 2 and 3.

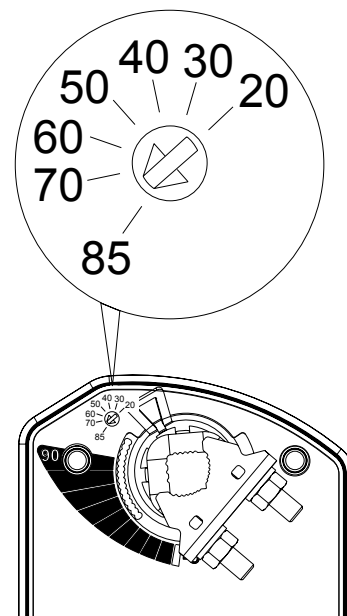

Auxiliary Switches (S)

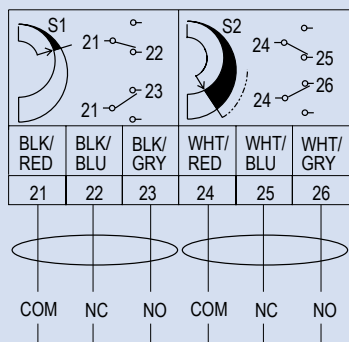

Limitation of rotation angle

Using the M9208-603 the angle of rotation can be limited. The actuator is factory set for 95° rotation, and its range is limited in 5° increments to a minimum of 35°.

Attaching the stroke-limiting stop in the furthest mounting position reduces the rotation range of the actuator by 5°. Each progressive position reduces the rotation range on additional 5°.

