

Series U255

Voltage Signal Input Fan Speed Controllers For Three Phase Motors (incl. built-in RFI suppression filter)

Introduction

These controllers are designed for applications where the fan speed must be controlled by a voltage input signal (e.g. 0-10V, 1-5V etc.) from a transmitter or control system.

The signal from one pressure transmitter connected to electronic pressostats, indicators and fan speed control eliminates pressure connections and capillaries through which possible loss of refrigerant is reduced. Head pressure control of a refrigeration system, through speed variation of the fan on an air-cooled condenser, results in optimum performance throughout the year.

The controller varies the supply voltage to the motor from 30% to at least 96% over the proportional band using the phase cutting principle. Motors that will be controlled by the U255 should not draw more than 5 A per phase.



U255
Fan Speed Controller

Feature and Benefits

<input type="checkbox"/> Adjustable voltage input.	Can be used for a wide range of voltage input signals.
<input type="checkbox"/> Allows connection in both "Star" and "Delta" configurations.	3 wire motor connection for both "Star" and "Delta" connection.
<input type="checkbox"/> Built-in suppression filter.	The control meets the electro magnetic compatibility requirements of the 89/336/EEC directive.
<input type="checkbox"/> Contact input to force output to max. or off.	Control interrupt possibility.
<input type="checkbox"/> Built-in power supply.	15 V dc power supply for sensor.
<input type="checkbox"/> Built-in direct/reverse action selector switch.	Easy change over from direct to reverse control action
<input type="checkbox"/> IP54 enclosure.	Can be mounted outdoor.
<input type="checkbox"/> Built-in set point adjustment.	Easy set point adjustment on application.
<input type="checkbox"/> Minimum speed or cut-off selection.	Selection to keep the fan running on minimum speed or to switch it off.
<input type="checkbox"/> Adjustable minimum speed or cut-off Adjustable maximum speed limit. Proportional band adjustment.	Maximum flexibility to adjust cooling capacity and/or to get the best motor performance.
<input type="checkbox"/> Adjustable hysteresis in cut-off mode.	Easy motor start by adjustable start voltage.
<input type="checkbox"/> Cosφ motor adjustment.	Optimum control and motor performance.

Electric motor selection

Care must be taken when selecting an electric motor as the controller uses the phase cutting principle for variation of motor speed. This will cause additional heat generation in the stator (motor winding) and the rotor of the motor, especially at medium speed.

At medium speed the current to the motor will be at its highest level whereas the cooling of the motor has already substantially decreased. Motors that are designed to handle this extra heat generation are preferred. The use of thermal motor winding protection switches is advised. Often (depending on the total application conditions) a class F motor should be used to handle the temperature increase. Motors with lower temperature classification might be interrupted by the temperature protection switches, which are embedded in the motor windings. Finally, the motor should have bearings that provide sufficient lubrication at lower RPM and possibly increased shaft temperatures.

It is recommended to confirm with the electric motor manufacturer, that the motor can be used with a controller, using the phase cutting principle for speed variation. You can also provide a copy of this U255 product data sheet to the motor manufacturer/supplier for review.

Note

At lower speeds (between 50% and 75% of rpm mentioned on the motor data plate), depending on motortype and load, the max. current can become higher than $I_{nominal}$ of the motor. In case the max. current increases above 5 Amp. the max. allowed ambient temperature will become lower as indicated in the diagram (see fig. 1).

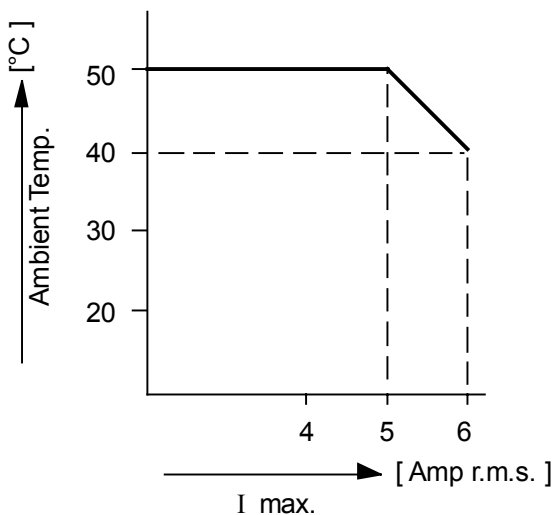

Fig. 1

Note

The U255 is intended to control equipment under normal operating conditions. Where failure or malfunction of the U255 could lead to an abnormal operating condition that could cause personal injury or damage to the equipment or other property, other devices (limit or safety controls) or systems (alarm or supervisory systems) intended to warn of or protect against failure or malfunction of the U255 must be incorporated into and maintained as part of the control system.

Installation

Mount the controller in a vertical position. The controller is provided with spacers to create at least 10 mm distance between the mounting surface and the heatsink. For proper air-circulation there should be a clearance around the controller of at least 50 mm. When mounted inside a cabinet, holes for air-circulation should be provided. If the U255 cannot be mounted vertically, additional limitations apply. The maximum allowable current will be 3.5 A instead of 5 A or the maximum allowable ambient temperature is reduced to 35 °C instead of 50 °C.

Wiring motor

The motor can be wired in Star or Delta. To meet the EMC directive shielded cable has to be used for motor wiring in case the distance between controller and motor is more than 2 meters. If the distance is less than 2 meters it is allowed to use non-shielded cable. (see fig. 2).

Non shielded cable may be used if the control and motor are mounted in one frame.

Both sides of the shield have to be connected. To prevent stray current, the two earth connections of the controller, the motor earth connection as well as the cable shield, all have to be connected to one earthing pole (see fig. 2).

More motors can be wired in parallel, provided that the total current will not exceed 5 A rms.

EMC

The controller does have a built-in suppression filter and meets all required EC directives. Please note that when two or more EMC compliant components are built together the total system may not be compliant. To make the total system compliant is the responsibility of the producer.

Wiring input signal

The voltage input signal must be wired according to fig.2. (terminal A is zero, B0 is 0-10V signal). A 15 Vdc power supply for a transmitter (5 mA max.) is available on terminal C.

Warning

The input signal to the control may not become lower than 0 V.

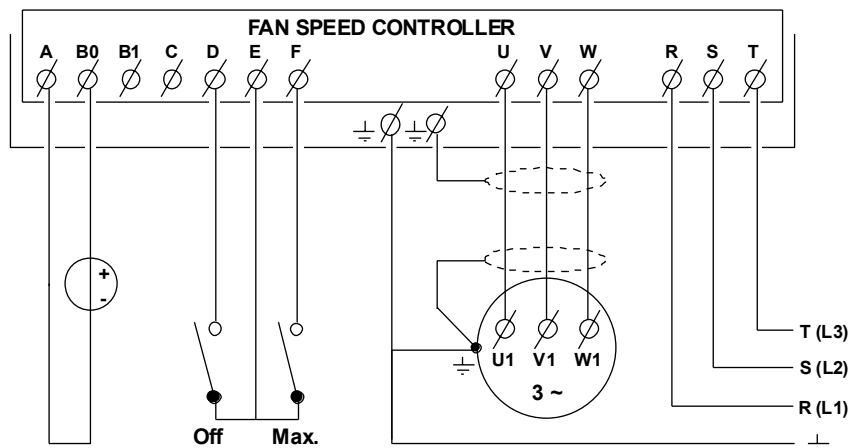

Fig. 2

Control action (direct/reverse)

The controller will be delivered for direct action (out-put voltage increases at increasing input signal voltage). If reverse action is desired this can be obtained by changing the direct/reverse switch to position "Reverse" (see fig. 4).

Max. speed / fan off

A potential free contact can be connected to the U255 to force the output to maximum (output $\geq 96\%$ of supply voltage) or to switch the fan off (see fig. 2).

Terminal E is the common. If E is connected to F the fan goes to max. speed. If E is connected to D the fan is switched off.

Measuring

For measuring amps or volts values a true rms meter should be used.

Caution

The U255 is not equipped with a power switch. Therefore an additional switch to isolate the device should be used in the power supply wiring to the U255.

For motor protection the use of thermal motor winding protection switches is preferred. If a thermal/current overload relay is used the max. current (between 50% and 75% of the speed) should be measured to set the overload relay. A larger difference between I_{nom} and I_{max} results in an insufficient motor protection.

Fuses

Controller damage, caused by too high load, will be prevented /limited by the built-in 10A glass fuses. In case of malfunctioning of the controller these fuses should be checked first.

For protection of the main power wiring external 400V NEOZED or 500V DIAZET fuses can be used. The required fuse amperage depends on the used wiring. See below table.

1 mm ²	6 Amp
1.5 mm ²	10 Amp
2.5 mm ²	16 Amp

Selection 50/60 Hz (see fig.4)

The control will be delivered for use on 50 Hz supply frequency. For 60 Hz selection the selector switch position must be changed to 60 Hz

Adjustments

The U255 gives a control characteristic according to fig. 3

The control characteristic is affected by the load and the supply voltage.

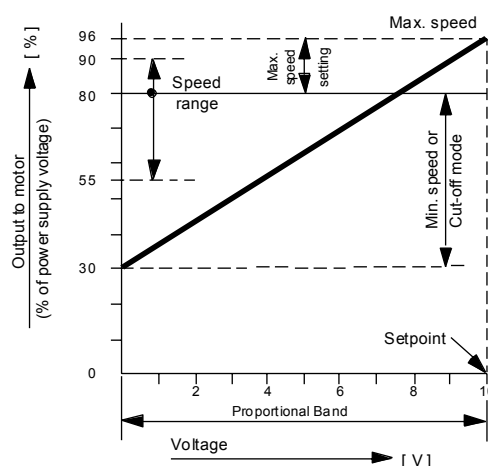

Fig. 3 Factory adjusted characteristic

Adjustable settings:

 (see Fig. 4 and 5)

Setpoint	0.5 to 10 V
Speed range	55 to 90% of supply voltage
Max. speed	55 to $\geq 96\%$ of supply voltage
Min. speed	30 to 90% of supply voltage
Cut-off	30 to 90% of supply voltage
Prop. band	0.7 to 10 V
Hysteresis	5 to 70% of adj. prop. band
$\text{Cos}\phi$	0.6 to 1

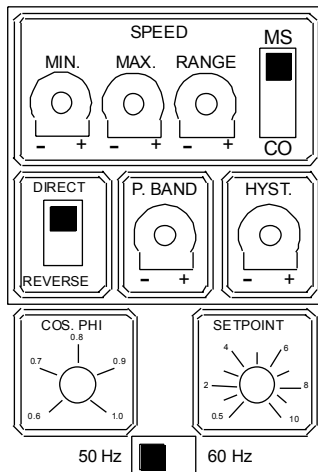

Fig. 4

Factory settings

Setpoint	10 V
Speed range	80%
Max. speed	$\geq 96\%$
Min. speed	30%
Prop. band	10 V
Hysteresis	5%
$\text{Cos}\phi$	0.8
MS/CO switch position	MS
50/60 Hz switch position	50 Hz
Direct/reverse switch position	Direct

The controller will be delivered with these settings.

Setpoint

The setpoint (point A) at which the control delivers maximum output can be adjusted by the "SET POINT" potentiometer (see fig. 4) inside the controller between 0.5 to 10 Volt

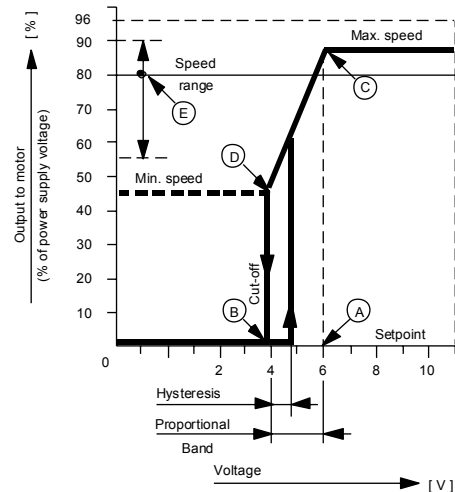

Fig. 5

Maximum speed limit

It is possible to adjust a maximum speed limit (point C). This means that the output to the motor will not increase above the adjusted setting. The maximum speed limit can be adjusted with potentiometer "MAX." inside the controller (see fig. 4). The maximum output voltage to the motor is adjustable from the adjusted speed range line up to $\geq 96\%$ of the power supply voltage.

Minimum speed

The minimum speed voltage setting (point D), to prevent fan speed reduction below desirable levels, can be adjusted from 30% of the power supply voltage up to the adjusted speed range line by means of potentiometer "MIN." inside the controller and selector switch MS/CO set to minimum speed mode MS (see fig. 4).

Speed range line

The max. speed adjustment is independent from the min. speed adjustment. To prevent that the min. speed is set to a higher value than max. speed (no output any more) the "speed range line" is introduced. This (imaginary) line divides the output characteristic into an upper part and lower part.

The maximum speed can be adjusted in the upper part (from $\geq 96\%$ down to the adjusted speed range value). The minimum speed/cut-off can be adjusted in the lower part (from 30% up to the adjusted speed range value). The speed range line (point E) can be adjusted with the speed "RANGE" potentiometer (see fig. 4) from 55% to 90% of the power supply voltage.

Cut-off mode

In the cut-off mode the output to the motor will drop to zero if the input signal decreases below point B. The fan stops.

The cut-off can be adjusted from 30% of the power supply voltage up to the adjusted speed range line by means of potentiometer "MIN." inside the controller and the selector switch MS/CO set to cut-off mode CO (see fig. 4).

Proportional band

The proportional band is the difference between the signal input voltage at which the output to the motor is 0 V (point B) or the minimum speed voltage (point D) and the signal input voltage value at setpoint (point A). The proportional band is adjustable with potentiometer "P-BAND" inside the controller (see fig. 4) from 0.7 V up to 10 V.

Hysteresis

A running fan can be controlled to a low speed. Sometimes it gives trouble starting at this low speed. Therefore it is possible to adjust the hysteresis which means the motor starts at a higher voltage. The hysteresis can be adjusted by potentiometer "HYST." between 5% and 70% of the adjusted proportional band (see fig. 4).

Cosφ

On the motor data plate the $\cos\phi$ of the motor is indicated. To get the most optimal control the "COSPHI" potmeter (see fig. 4) must be set to this value. If $\cos\phi$ is not known the potmeter can be set to 0.8

Repair and replacement

Repair is not possible. In case of an improperly functioning control, please check with your nearest supplier. When contacting the supplier for a replacement you should state the type-model number of the control. This number can be found on the data plate.

Type number selection

Order nr.	Supply voltage
U255MM-9100	400 V - 3 phase

Dimensions (mm)

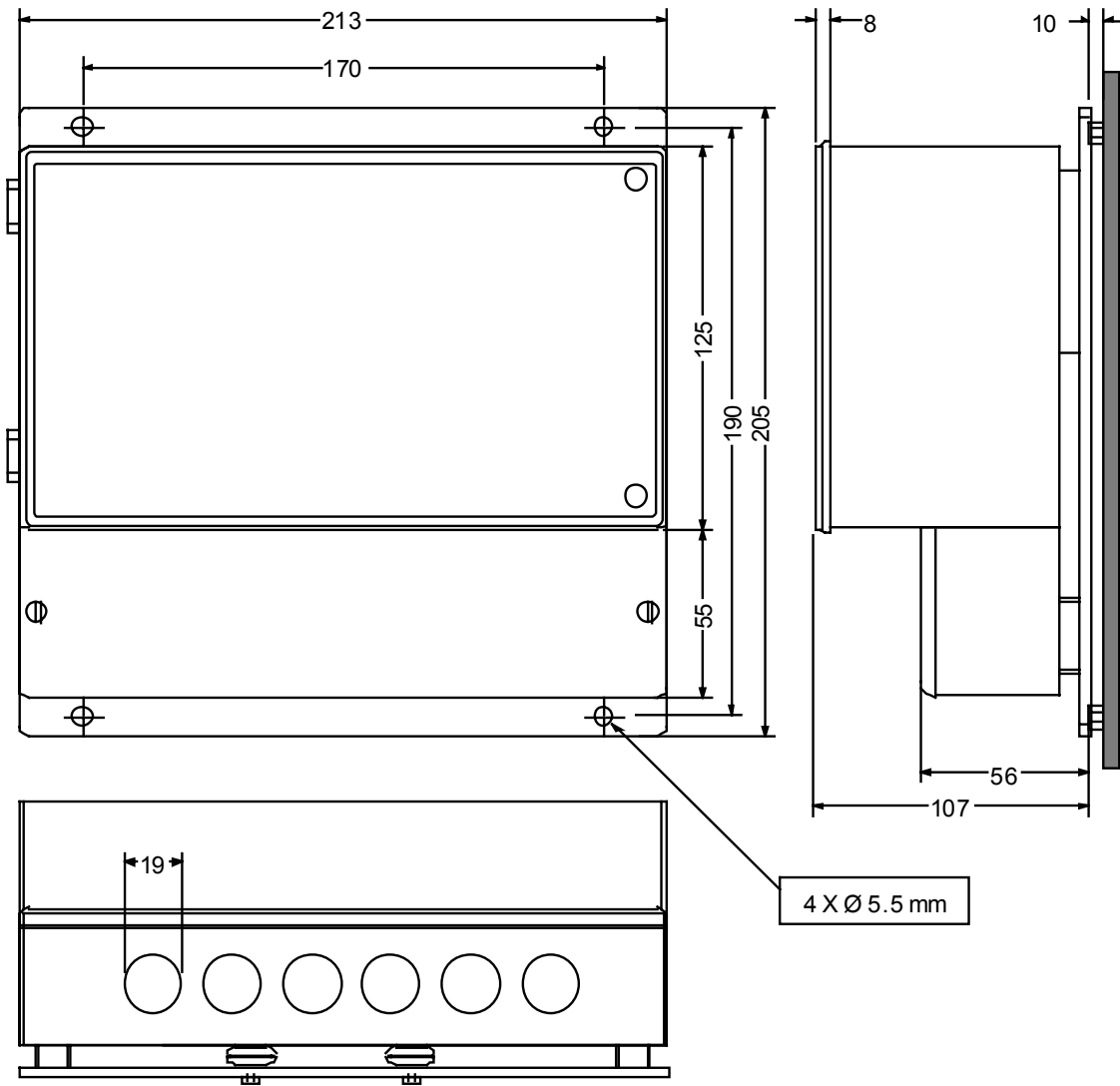

Fig. 6

Note

Specifications

Product type	U255
Power supply for transmitter	15 V dc max. 5mA.
Input	Voltage input 0 to 10 V or within range 0 to 10 V. Input impedance 1 M Ohm
Control action	direct/reverse
Maximum output voltage	≥ 96% of supply voltage
Maximum current	5 A per phase (rms)
Minimum current	0.1 A per phase (rms)
Power factor (cosφ) motor	≥ 0.6
Power consumption	nominal 1.5 VA
Mains supply voltage	U255MM 400V 3 phase +10%/-15%
Mains supply frequency	50/60 Hz
Operating ambient temp.	-25 to +50 °C
Operating /storage ambient humidity.	10 to 98 % R.H. (non-condensing)
Storage ambient Temp.	-40 to 70 °C
Max. speed adjustment	55 to ≥ 96 % of supply voltage
Min. speed/ cut-off adjustment	30 to 90 % of supply voltage
Prop. band	0.7 to 10 V
Hysteresis	5 to 70% of the adjusted prop. band
Enclosure	IP54
Fuses	10 Amp. slow blow glass fuse
Material: case and cover	Polystyrol
heatsink	aluminium
Shipping weight	2.0 kg
Residual current motor	in cut-off mode ≤ 15 mA
Wiring connections	screw terminals 1 mm ² up to 2½ mm ²
Dimensions	213 x 205 x 117 (WxHxD)

The performance specifications are nominal and conform to acceptable industry standards. For applications at conditions beyond these specifications, consult the local Johnson Controls office or representative. Johnson Controls shall not be liable for damages resulting from misapplication or misuse of its products.



Johnson Controls International, Inc.

Headquarters: Milwaukee, WI, USA
 European Headquarters: Westendhof 8, 45143 Essen, Germany
 European Factories: Lomagna (Italy), Leeuwarden (The Netherlands) and Essen (Germany)
 Branch Offices: Principal European Cities.

This document is subject to change

Printed in Europe