

M9216-HGx-1
Modulating Spring Return Actuator

Application

The **JOHNSON CONTROLS** electric, Spring Return damper-actuator series has been specially developed for the motorized operation of safety air dampers (anti-icing) in air conditioning systems, smoke evacuation dampers and sealing dampers. When the control signal is applied the actuator drives the damper to the operational position, while evenly tensioning the integrated spring. After a power failure the stored energy in the spring immediately brings the damper to the safety position.

Manual operation is automatically cancelled when the actuator is in electrical operation. The compact design and universal adapter fitted with limitation of rotation angle make this actuator highly versatile.

Features

- DC 0...10 V or 0...20 mA control
- Load independent running time
- Up to 5 actuators in parallel operation possible
- Plug-in terminal block connection
- Simple direct mounting with universal adapter on Ø 10 mm to 20 mm shaft or 10 mm to 16 mm square shaft 77 mm min shaft length
- Selectable direction of rotation
- Limitation of rotation angle
- Manual positioning with crank handle
- 2 adjustable auxiliary switches (See back page for settings)
- Automatic shut-off at end position (overload switch)
- Energy saving at end positions
- Actuators available with 1 m halogen-free cable
- Customized versions available
- Devices meet CE requirements

Accessories

- ZK damper linkage selection
- ZKG ball joints (see data sheet 6.10)



Technical Specifications

Actuator	M9216-HGx-1
Torque	16 Nm
Damper area*	3.0 m ²
Running Time Motor	90 s
Running Time Spring Return	10 s
Supply Voltage	AC/DC 24 V
Frequency	50-60 Hz
Power Consumption	
- Running	7.0 W
- At end position	0.6 W
Dimensioning	12.0 VA / 6 A @ 2 ms
Control Signal	
- Y1	DC 0...10 V
- Y2	0...20 mA
Position Signal	DC 0...10 V
Angle of rotation/Working range	90° (93° mech.)
Angle of rotation/Limitation	0°...30° and 90°...60°
Auxiliary Switches	3(1.5) A, AC 230 V
- Setting range	5°...85°
Life time	60.000 rotations
Noise level	50 dB (A)
Protection Class	II
Degree of Protection	IP 54
Cable aperture connections	PG11
Mode of Action	Type 1
Ambient conditions	
- Operating temperature	-20...+50 °C / IEC 721-3-3
- Storage temperature	-30...+60°C / IEC 721-3-2
- Humidity	5...95% r.F. no condensed
Weight	2.7 Kg
Service	Maintenance-free
Standards	
- Mechanics	EN 60 529 / EN 60 730-2-14
- Electronics	EN 60 730-2-14
- EMC Emissions	EN 50 081-1:92 / IEC 61000-6-3:96
- EMC Immunity	EN 50 082-2:95 / IEC 61000-6-2:99

*Caution: Please note damper manufacturer's information concerning the open/close torque.

Ordering Codes

Codes	Descriptions
M9216-HGA-1	AC/DC 24 V
M9216-HGC-1	AC/DC 24 V, with 2 auxiliary switches

M9216-HGx-1
Modulating Spring Return Actuator

Wiring Diagram

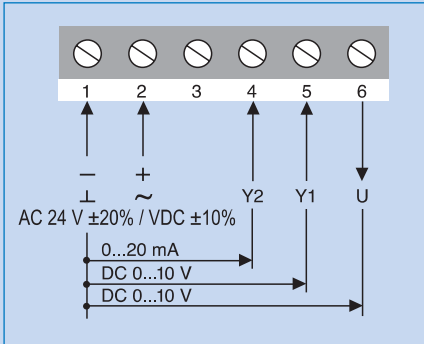

Parallel Connections

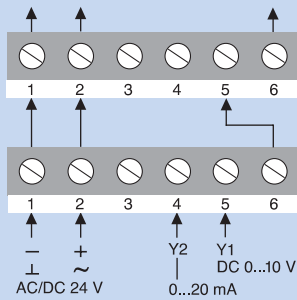

For parallel operation of the actuators, the DC 0...10 V output signal U = DC 0...10 V is connected, from the master actuator trough terminal 6, to the slave actuator trough terminal 5 etc.

Caution: Parallel connection of up to a maximum of 5 actuator possible.

Position transmitter

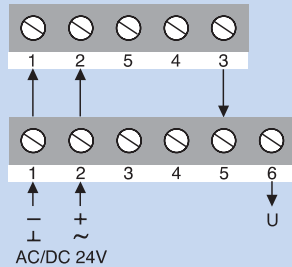

The actuator can also be controlled using the Johnson Positioner (PA-PF) with Control signal of DC 0...10 V. For further information concerning the PA and PF Positioner please refer to data sheet 6.20.

Dimensions in mm

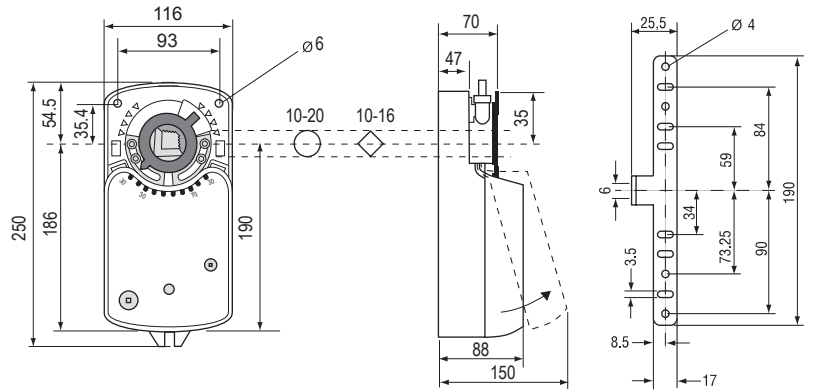

Actuator open

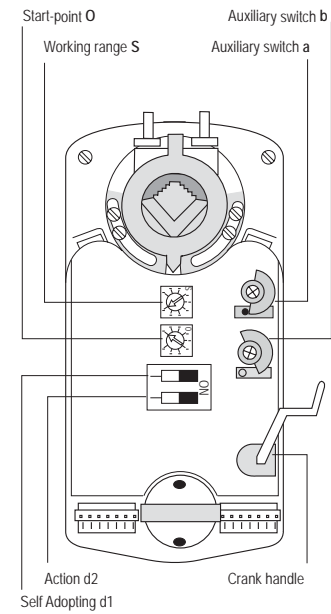

Changing the direction of rotation

The change in rotation direction is achieved by removing the adapter bush from one side and replacing it on the other side.

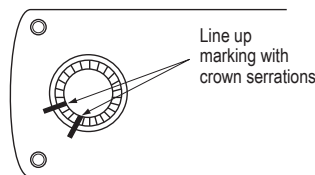

Factory setting:
Clockwise rotation.

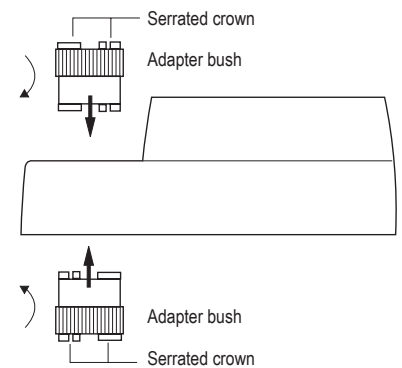

M9216-HGx-1
Modulating Spring Return Actuator

Override Control

The actuator can also be forced to override control when wired in accordance with the diagram.

Switch position:
 1 = Actuator runs at 10 V
 2 = Actuator runs at 0 V
 3 = Automatic control operation

Auxiliary Switches

3(1.5)A, AC 230 V
Actuator at 0° position

Action Setting

The action setting of control signal Y1 and Y2 can be reversed by switching the microswitch d2. This reverses the action of the output signal U.

Normal operation.
By increasing control signal Y1 and Y2, tensioning of the spring will occur.



Reversed operation.
By decreasing control signal Y1 and Y2, tensioning of the spring will occur.

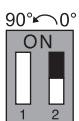

Control Signal: Factory setting

Control signal Y1 Input Resistance	DC 0...10V Ri = 200 kΩ
Control signal Y2 Input Resistance	0...20 mA Ri = 388 Ω
Position signal U1 Load resistance	DC 0...10 V R ≥ 10 kΩ

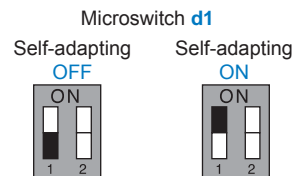

The self-adapting mode is activated by switching the micro-switch d1 to ON. In this mode the running time, control signals Y1 and Y2 and the output signal U will set to match the mechanically selected range of rotation. The minimum working range that can be adapted to is 30°. During the self-adapting procedure the actuator finds and stores both end positions. Even after a power failure the stored values can be recalled. If the angle of rotation is changed the actuator will automatically match the new working range.

Changing the control setting

The potentiometers **O** and **S** help to match control signals Y1 and Y2 to any make of controller.

Example 1

Control signal Y1 working between DC 2...10 V
 Setting: Starting point **O** = 2
 working range **S** = 8

Example 2

Control signal Y2 working between 6...18 mA
 Setting: Starting point **O** = 3
 Working range **S** = 6

Start point O

	Scale O	0	1	2	3	4	5	6	7	8
	for Y1 (VDC)	0	1	2	3	4	5	6	7	8
	for Y2 (mA)	0	2	4	6	8	10	12	14	16

Working range S

	Scale S	2	3	4	5	6	7	8	9	10
	for Y1 (VDC)	2	3	4	5	6	7	8	9	10
	for Y2 (mA)	4	6	8	10	12	14	16	18	20

Setting the auxiliary switches

Factory setting
 Switch **a** at 10°
 Switch **b** at 80°

The switching position can be manually changed to any required position by turning the ratchet

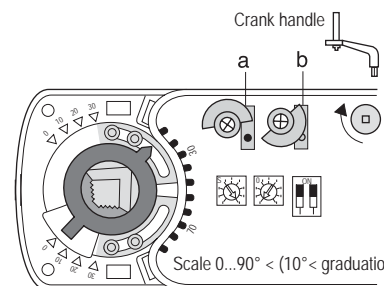

Limitation of rotation angle

The 90° angle of rotation/working range can, through segments 1 and 2, be reduced by up to 30° from both end positions.

