

FA-3300 Heavy Duty Electric Actuator

Introduction

The FA-3300 series synchronous motor-driven, reversible, heavy duty actuators are available for 3-point (floating) or with electric positioner for 0...10 V or 0...20 mA control. They feature factory calibrated pressure switches to provide specified close-off ratings.

These actuators are available with 6000 N nominal force and can be used in combination with VG8000 and VBD series valves in accordance with the maximum close-off pressure ratings specified.

Factory fitted options, such as 2 k Ω feedback potentiometer and auxiliary switches are available. A hand wheel for manual positioning of the valve is standard on all models.



FA-3300 Actuator with VG8000 valve

Features and Benefits

<input type="checkbox"/> Uses synchronous motor with calibrated pressure limit switches.	Constant running time. Fixed close-off force.
<input type="checkbox"/> Special clamp coupler.	Provides easy mounting of the actuator on valves with slotted stem.
<input type="checkbox"/> Models for 3-point and proportional 0...10 V or 0...20 mA control.	Allows optimum choice of electrical signal.
<input type="checkbox"/> Positioner with adjustable starting point, span, and direct / reverse action.	Provides flexibility in application. Allows easy sequencing from only one controller output signal.
<input type="checkbox"/> Active 0...10 V position feedback on proportional models.	Provides active signal for independent monitoring of position.
<input type="checkbox"/> Optional auxiliary switches and feedback potentiometer available.	Provides potential free contacts for independent monitoring of the actuator's position.
<input type="checkbox"/> A hand wheel is standard on all models.	Allows manual positioning independent from power supply.

Ordering data

FA-	□□	-741	□
Actuator Supply voltage*			
1	230 VAC, 50 Hz		
6	24 VAC, 50 Hz		
Accessories, factory mounted			
00	None		
03	Two auxiliary switches and 2 kΩ feedback pot.		
04	135 Ω feedback pot.		
41	Built-in electronic Positioner 0...10 V / 0...20 mA and two auxiliary Switches		

*) For other supply voltage and frequency, please contact your Johnson Controls supplier.

Ordering Procedure

The valves and actuators can be ordered as separate units or a factory fitted combination. Should such a combination be required, please add "+M" after the order code for the actuator.

For example:

For a 2-way valve, DN 65, k_{VS} 63, PN16 plus actuator with electric positioner 0...10 V input, 24 V / 50 Hz supply, order:

Item 1 **VG82G1S1N** (valve body)
 Item 2 **FA-3341-7416** (actuator)

Alternatively, to order a factory fitted combination:

Item 1 **VG82G1S1N** (valve body)
 Item 2 **FA-3341-7416+M** (actuator)

Accessory Kits for in-situ installation:

EQ-1003-7101	Two Auxiliary Switches and Feedback Potentiometer 2 kΩ
EQ-1013-7101	Feedback Potentiometer 135 Ω

Repair parts:

EQ-1015-7101	Electric Positioner 0...10 V or 0...20 mA plug-in module for in-situ replacement.
---------------------	---

Actuator-Valve combinations

The FA-3300 series heavy duty electric actuators are specifically designed to be used with the VG8000 and the VBD valve series. The ordering data for these valve bodies are as follows:

● VG8000 series (PN16 flanged valves)

VG82□□S1N	2-way PDTC (NO)	DN 100...150
VG88□□S1N	3-way mixing	DN 100...150
VG89□□S1N	3-way diverting	DN 100...150

● VBD series (PN25 flanged valves)

VBD-□□ 12-520□	2-way PDTC (NO)	DN 80...150
VBD-□□ 18-520□	3-way mixing	DN 80...150

Please refer to the product bulletins "VG8000 Series Flanged Valves" and "VBD Series Flanged valves" for complete ordering information.

Operation

3-point models

Connections	Actuator Stem
1-2	extends
1-3	retracts

Proportional models

Action Jumper	Input control signal	Actuator Stem
Direct acting	increases decreases	retracts extends
Reverse acting	increases decreases	extends retracts

Mounting instructions

When mounting the actuator on a valve, please follow the instructions below:

- It is recommended that the valves be mounted in the upright position, in an easily accessible location. When mounted horizontally, the yoke should be fitted such that the stanchions are positioned vertically one above the other.

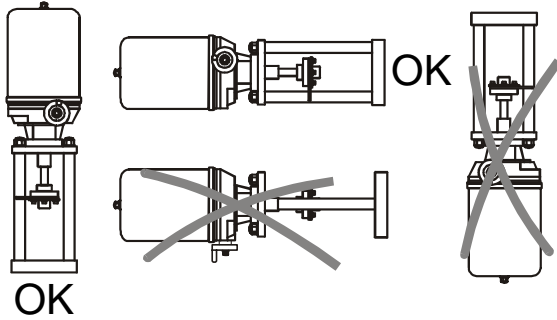

- The actuator must be protected against dripping water, which could enter the housing and damage the mechanism or motor.
- Do not cover with insulating material.
- Sufficient clearance must be allowed for actuator removal (refer to the dimension drawings).
- The valve must be installed so that the plug seats against the flow as indicated by the arrow(s) on the valve.

Wiring instructions

- All wiring must be in accordance with local regulations and national electrical codes and should be carried out by authorised personnel only.
- Make sure that the line power supply is in accordance with the power supply specified on the device.
- See also the instructions in paragraph "Application".

! WARNING

Shock Hazard

Disconnect the power supply before wiring connections are made to prevent personal injury.

Equipment Damage Hazard

Make and check all wiring connections before applying power to the system. Short circuited or improperly connected wires may result in permanent damage to the unit.

Wiring diagrams

3-point models

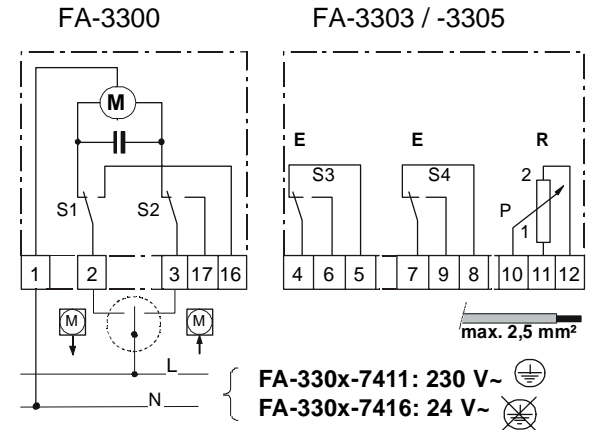

Proportional models

FA-3341

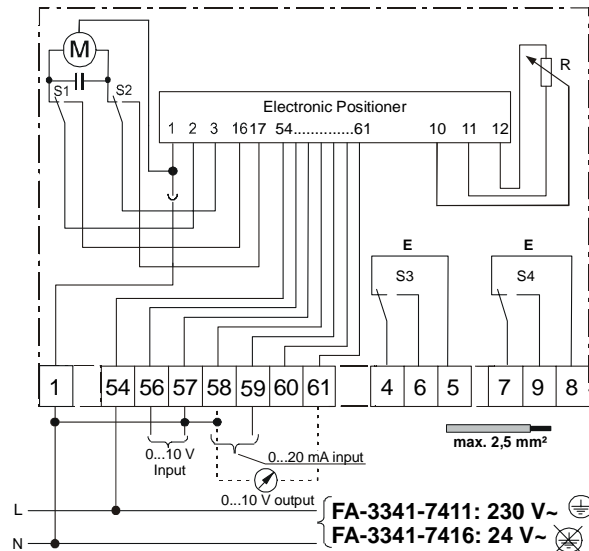

Adjustments

! WARNING

Shock Hazard

Great care must be taken when the cover is removed (by authorised personnel only) for adjustment or inspection.

In all other cases when the cover is removed the power must be switched off.

Do not touch or attempt to connect or disconnect wires when the electrical power is on.

Actuators with 0...10 V or 0...20 mA positioner (example below with 0...10 V)

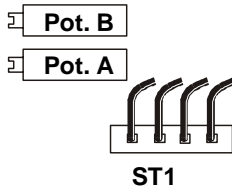

Selecting positioner action:

The action can be selected by disconnecting plug "ST1", turning it 180 degrees and reconnecting it, as in the following illustration:



Slope adjustment:

• **Direct Action:**

At the **maximum** input signal, adjust the 0% position with "potentiometer A".

At the **minimum** input signal, adjust the 100% position with "potentiometer B".

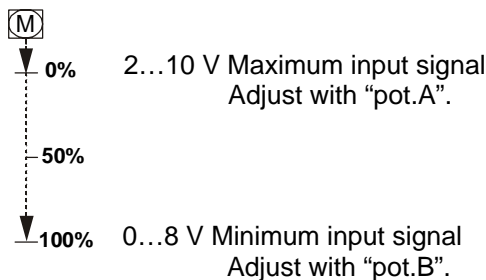

• **Reverse Action**

At the **minimum** input signal, adjust the 0% position with "potentiometer A".

At the **maximum** input signal, adjust the 100% position with "potentiometer B".

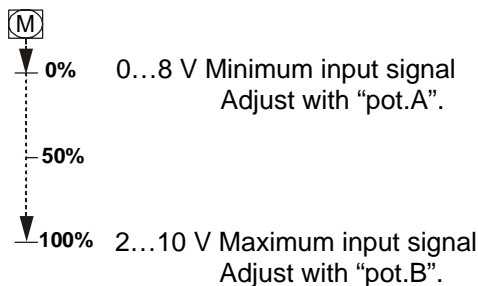

Note:

The maximum input signal must always exceed the minimum input signal by at least 2 Volts.

Applications

Parallel and sequenced operation of actuators

CAUTION

Parallel connection is only possible using isolation relays. If the parallel running motors do not have separately switched power supplies one or more motors will start to cycle at the end of travel.

Actuators with built-in positioner for controllers with 0...10V output

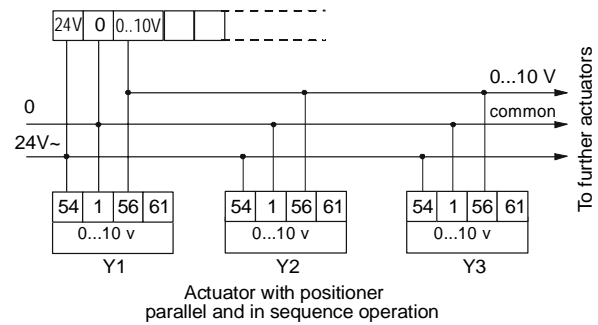

The controller output 0...10 V can operate several actuators with electronic positioner for 0...10 V or 0...20 mA control. The electrical wiring for parallel and sequenced operation is identical. The sequencing and action of the actuator can be adjusted individually on each positioner. Each positioner has its own adjustment for starting point between 0...8 V and end point between 2...10 V. Using the minimum adjustable span of 20 % therefore enables a maximum of 5 sequenced devices. Further sequencing can be accomplished by using additional controller outputs. Each positioner can be set for direct or reverse action.

Adjustments for Y1, Y2 and Y3 (example)

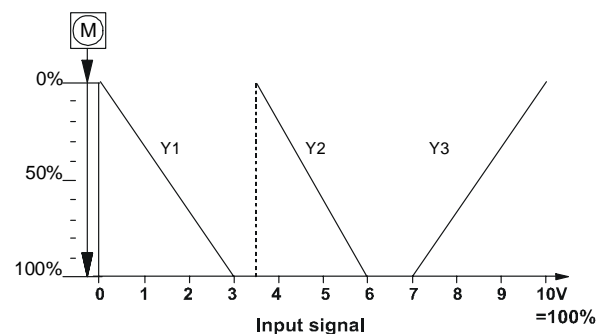

Reversible actuator without positioner for floating controller.

Sequencing two actuators without positioner using end switches.

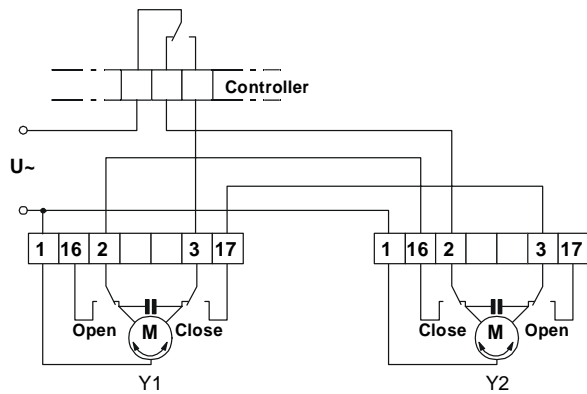

Parallel operation of actuators without positioner with synchronous motor, condenser and end switches:

Although synchronous motors have the same running speed, deviation in travel between motors can accumulate because of varying load during start-stop operation. This deviation depends on the number of on/off cycles and is about 0,5 % per 100 cycles. Periodically switching the actuators to end of travel (e.g. normal position) will improve the synchronous running of the motors.

Dimensions in mm

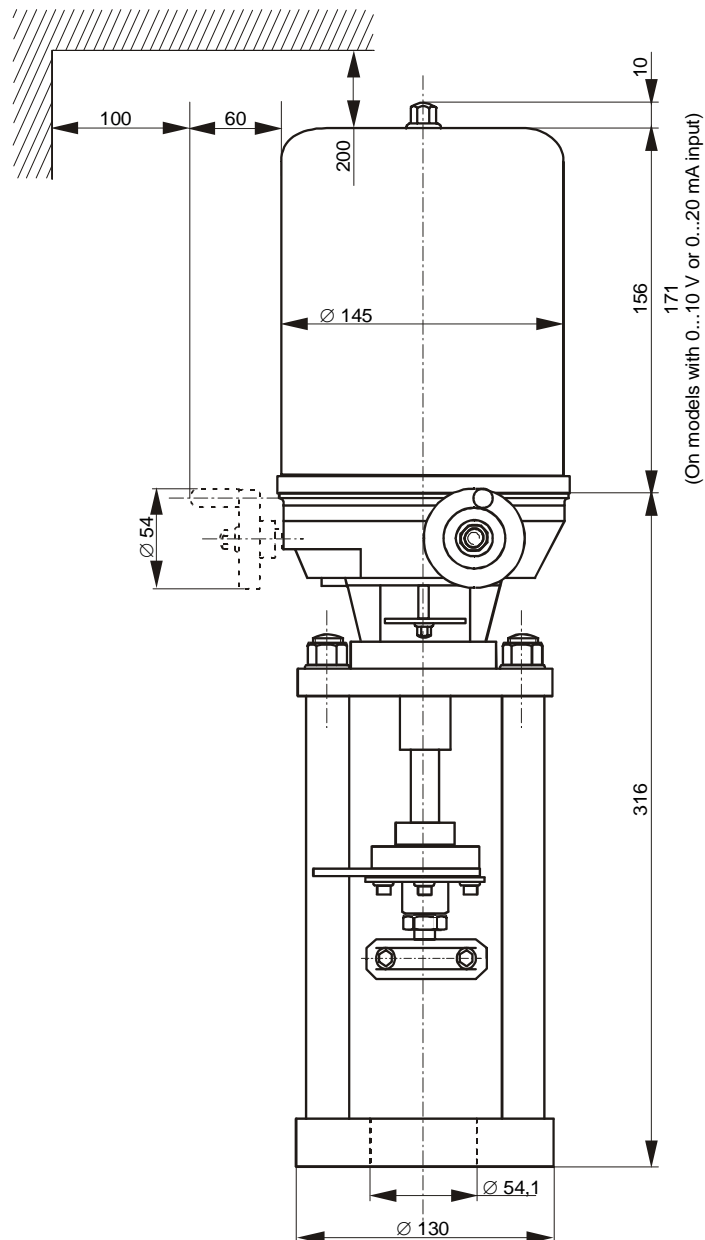

Specifications

Actuator models	FA-33xx-741x
Associated valve series and body sizes	<ul style="list-style-type: none"> • PN16: VG8000 DN 100...150 • PN25: VBD DN 80...150
Type of motor	Synchronous, Reversible
Action / Control	<ul style="list-style-type: none"> • 3-point • 3-point with 5(3) A / 250 VAC auxiliary switches and 2 kΩ or 135 Ω feedback potentiometer • Proportional with built-in 0...10 V or 0...20 mA electronic positioner (input impedance 10 kΩ) and with 5(3) A / 250 VAC auxiliary switches
Hand wheel	Standard on all models
Supply voltage and frequency*)	24 VAC +10% / -15%, 50 Hz 230 VAC +10% / -15%, 50 Hz
Power consumption (with positioner)	37 VA (42 VA)
Nominal force	6000 N + 300 N
Nominal stroke	42mm; Max. 45mm
Nominal running speed	17mm / min
Enclosure Protection	IP 65
Materials:	
Stem	Stainless steel (material DIN W-Nr. 1.4305)
Cover	Pressed sheet steel (lacquered)
Operating and Storage Conditions	-20...+60 °C R.H. 10...90 %, non condensing
Electrical Connection	screw connector 2,5 mm ²
Cable relief	1 x PG 11
Net weight	7,5 kg
Approvals	European Directives: EMC (89 / 336 / EEC) LVD (73 / 23 / EEC)

*) For other supply voltage and frequency, please contact your Johnson Controls supplier.

The performance specifications are nominal and conform to acceptable industry standards. For application at conditions beyond these specifications, consult the local Johnson Controls office. Johnson Controls, Inc. shall not be liable for damages resulting from misapplication or misuse of its products.

Johnson Controls International, Inc.

Headquarters: Milwaukee, WI, USA

European headquarters: Westendhof 8, 45143 Essen, Germany

European Factories: Lomagna (Italy), Leeuwarden (The Netherlands), Essen (Germany)

Branch Offices: principal European Cities

Printed in Germany